

Packaging Specification for 7" Reel SMD Diodes & Transistors

1. The method of packaging and dimension are shown as below figure. (Dimension in mm)

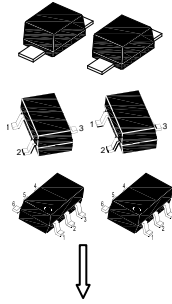

SOD-123FL
SOD-123HE
SOD-323
SOD-323HE
SOT-23
SOT-26

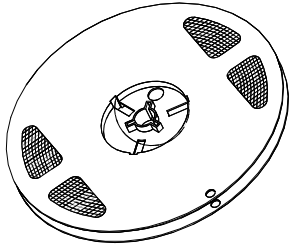

SOD-123FL, SOD-123HE, SOD-323, SOD-323HE,
SOT-23, SOT-26: 3,000 pcs per reel

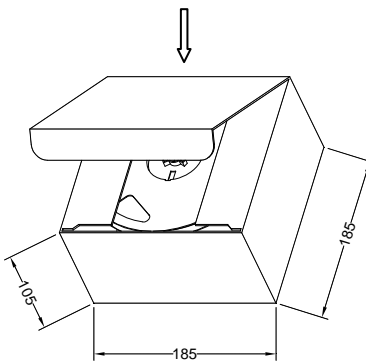



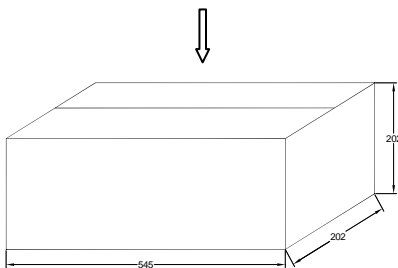

SOD-123FL, SOD-123HE, SOD-323, SOD-323HE,
SOT-23, SOT-26 : 24,000 pcs per box
8 reels per box



SOD-123FL, SOD-123HE, SOD-323, SOD-323HE, SOT-23,
SOT-26: 120,000 pcs per carton
5 boxes per carton

2. Label

2.1 The information of inner box label must be listed: (Description of a sample lable)

- 2.1.1 TYPE **1N4007W-HAF** means (Product) TYPE (Part No.)
- 2.1.2 QTY 3,000 PCS  0814052 means (Product) Quantity (QTY)
- 2.1.3  means Dice Lot No. / Code (D/C)
- 2.1.4 D/C NY1A9M0702R1  means Production Code (P/C)
- 2.1.5 P/C DDAD80013-JIC0001  RMK30820 means Manufacturing Date (RMK)

2.2 The information of carton label must be listed:

- 2.2.1 TYPE
- 2.2.2 QTY

TOP DYNAMIC



ISO14001 : 2004 Certificate No. 121505007
ISO 9001 : 2008 Certificate No. 50114012
OHSAS 18001 : 2007 Certificate No. 05131500006
IECQ QC 080000 Certificate No. E03H10027 V4.002

Dated: 15/09/2015 Rev: 02